

*Project* Generally valid  
*Document no.* KP-12.MA-02  
*Status* Released  
*Document type* Specification  
*Number of pages* 20

# Logistics Guideline

## Stadler Deutschland GmbH



Index	Amendment	Date	Complied by	Reviewed by	Released by
1.0	First edition	08.07.2020	Julian Uher	Jonas Hensel	Till v. Levezow
2.0	Shipping instruction	28.08.2020	Julian Uher	Jonas Hensel	Till v. Levezow
3.0	Checklist	16.12.2020	Sebastian Werner	Jonas Hensel	Till v. Levezow
4.0	7.4 Customs documents	29.03.2021	Paul Wildt	Sebastian Werner	Thomas Schmitz
5.0	7.4 Customs documents	20.04.2021	Paul Wildt	Sebastian Werner	Thomas Schmitz
6.0	Complete revision	26.01.2022	Dustin Grzywna	Tommy Mader	Anna Maria Lang

## Content

1. General .....	1
1.1. Environment management .....	1
1.2. Contact partners .....	1
1.3. Definition of terms.....	1
2. Load unit, Load carrier and packaging .....	2
2.1. Load unit.....	2
2.2. Load carrier and packaging .....	3
2.2.1. Division of the load carrier.....	3
2.2.2. General requirements .....	3
2.2.3. Protection of the materials in load carriers and the packaging.....	4
2.2.4. Specific requirements for the packaging .....	4
2.2.5. Structure of non-standard load carriers.....	5
2.2.6. Economic and ecological aspects .....	5
2.3. Formation and description of the delivery .....	6
2.3.1. Description of the delivery .....	6
2.3.2. Formation of the delivery.....	7
3. Labelling.....	8
3.1. Labelling materials.....	8
3.1.1. Minimum requirements of the label and print .....	8
3.1.2. Identification of components with item number .....	8
3.1.3. Identification of components with required serial numbers .....	9
3.2. Labelling packaging.....	9
3.2.1. Minimum requirements for the label and print .....	9
3.2.2. Content of the label.....	10
3.3. Labelling non-standard load carriers .....	10
3.4. Other labeling .....	10
4. Shipping documents.....	11
4.1. Delivery note .....	11
4.2. Packing list .....	12
4.3. Consignment note or waybill .....	12
4.4. Customs clearance and customs documents .....	12
5. Supply process .....	14
5.1. Procurement process .....	14

5.2.	Outgoing goods inspections .....	14
5.3.	Loading and unloading .....	14
5.4.	Transport and dispatch.....	14
5.4.1.	Shipping instruction inbound.....	14
5.4.2.	Address Stadler Deutschland GmbH .....	15
5.4.3.	Dispatch of hazardous good .....	16
5.5.	Delivery .....	16
5.5.1.	Opening times incoming goods.....	16
5.5.2.	Registration transport.....	16
5.5.3.	Goods acceptance .....	16
5.6.	Empties management.....	17
6.	Enclousure .....	18
6.1.	Attachment 1: Different regulation of the logistics guideline .....	18
6.2.	Attachment 2: Selection of the load units .....	19
6.3.	Attachment 3: Checklist for inspection of outgoing goods to Stadler Deutschland GmbH .....	20

## 1. General

The supplier must observe and comply with the current valid Stadler Deutschland GmbH logistics guideline. In addition, the valid statutory regulations and requirements need to be applied. If you not observe the guideline and the legal regulations the supplier must bear the cost (processing fees, additional costs etc.).

### 1.1. Environment management

Stadler Deutschland GmbH is aware of its responsibility to conserve existing resources and avoid waste, wastewater and emissions. Therefore, it attaches great importance to the continuous and systematic improvement of environmental protection measures, especially when planning and optimizing the load carriers and packaging solutions.

Stadler Deutschland GmbH has a certified environmental management system in accordance with the currently applicable standards DIN EN ISO 14001 and DIN EN ISO 50001 and also ensures compliance with the principles of these standards when selecting and evaluating suppliers. Stadler Deutschland GmbH reserves the right to obtain information from the supplier for the life cycle assessment of its products.

### 1.2. Contact partners

The respective of STAP-purchaser is the first point of contact for all technical and commercial issues relating to the supplier. Other contacts for concrete topics are listed in the following chapters.

### 1.3. Definition of terms

The table below contains explanations of the terms used in this document.

Table 1: Definition of terms

Designation	Description
Stacking frame	Frame for Euro pallet
Euro pallet	Load carrier acc. To DIN EN 13698-1
Lattice box pallet	Load carrier acc. To DIN EN 13626
KLT	Small load carrier
Load unit	Package ready for shipment or a combination of the packing unit and the load carrier
Load carrier	Tool for the internal and external transport and/or the storage process
Complaint	Official letter in case of noncompliance with requirements
Packing unit	Created when material packaged
Packaging	Generic term for all packaging elements

Doc.No.: KP-12.MA-02	Stadler Deutschland GmbH	Version:	Release Date:	Created:	Checked:	Approved:
	<a href="#">Logistics Guidline</a>	6.0	27.01.2022	D. Grzywna	T. Mader	A. M. Lang

## 2. Load unit, Load carrier and packaging

The following characteristics and requirements must apply to the particular load units, load carriers and packaging, therefore they can be used. Stadler Deutschland GmbH must approve of exceptions in writing.

### 2.1. Load unit

All load units must be designed to have a stable form and make optimum use of the volume. Also, load units may not exceed the basic dimensions of the load carrier and a max. height of 1.1 m.

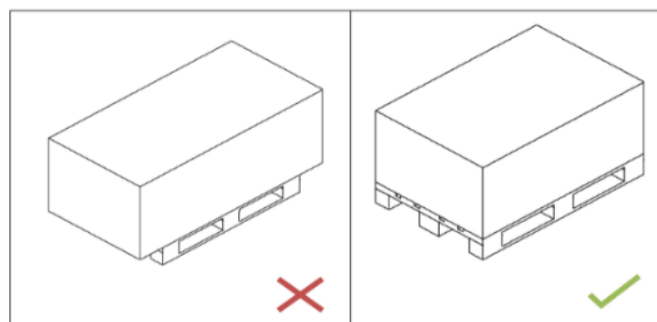

Figure 1: Basic dimensions of load unit

Load units and packages also need to be secured using straps, shrink film or stretch film to prevent them slipping during transport. If the transport lock needs to be re-released, the material must remain in a stable position (upright). Straps applied around the load unit must be made of plastic and have an edge protection profile. Also, the straps must surround the load unit at least once on the long side and once on the face side (see Figure 2). Also, all load units must have a stacking factor of at least two (see Figure 3).

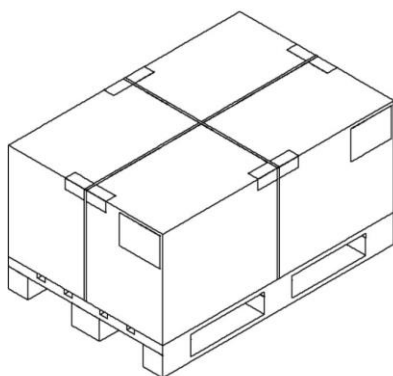

Figure 1: Load units ready for dispatch

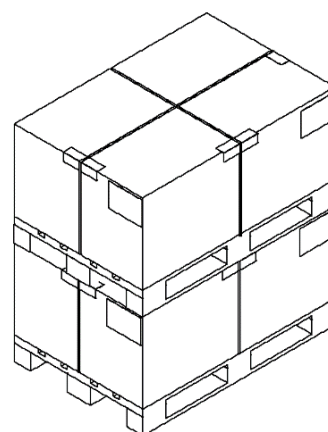

Figure 2: Load unit with a stacking factor of two

Doc.No.: KP-12.MA-02	Stadler Deutschland GmbH	Version:	Release Date:	Created:	Checked:	Approved:
	Logistics Guideline	6.0	27.01.2022	D. Grzywna	T. Mader	A. M. Lang

## 2.2. Load carrier and packaging

The load carrier and the packaging have a protection, storage and transport function, and carry information. Additionally, they also combine packages into load units.

### 2.2.1. Division of the load carrier

At Stadler Deutschland GmbH, load carriers can generally be divided into standard load carriers and non-standard load carriers.

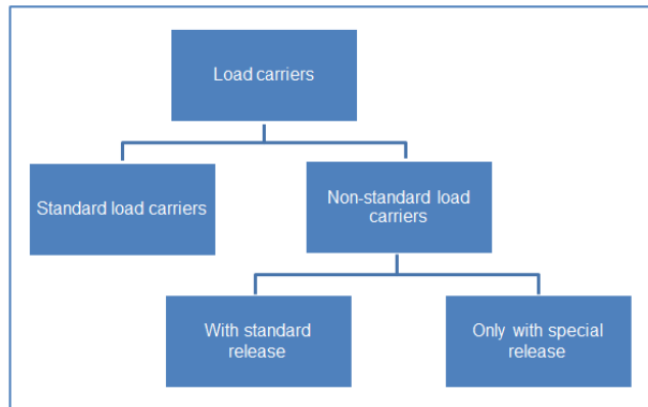

Figure 3: Division of load carriers

In general, standard load carriers should be used for all deliveries if the requirements from section 2.3. (Delivery variant 2) are satisfied.

### 2.2.2. General requirements

The load carriers and the packaging material must be ensured so that (dimensioning and configuration) the emergence of qualitative and quantitative defects of the goods during transport, storage and handling can be excluded. All load carriers and packaging must be able to withstand the dynamic and static forces generated during transport and storage.

More over load carrier and packaging must comply to the following requirements.

- Design must be dimensionally stable
- Safe to not get out of place, even during stacking
- Injury proof design (e.g. rounded edges, shatterproof)
- Must be able to be opened and closed by one person and without any devices<sup>1</sup>
- Screwing inside the load carriers or lids should be avoid

<sup>1</sup> safety cutter are allowed

Doc.No.: KP-12.MA-02	Stadler Deutschland GmbH	Version:	Release Date:	Created:	Checked:	Approved:
	Logistics Guidline	6.0	27.01.2022	D. Grzywna	T. Mader	A. M. Lang

## 2.2.3. Protection of the materials in load carriers and the packaging

All materials must be protected from short-term exposure to the elements<sup>2</sup> and damp, dust and dirt. In addition, the load carrier and the packaging must be designed so that the material cannot be damaged if transported or stored correctly (e.g. by impacts). The material should also have a secure fit in the load carrier<sup>3</sup>.

Sensitive materials<sup>4</sup> (e.g. electrical materials) should have the following protective measures:

### Surface treated components

Surface treated components must be packaged individually or after an approval from purchasing also in order lots. The components must be marked on the overpack (look at chapter 3.1.).

### Sensitive electrical material

Sensitive electrical materials need to be supplied in ESD<sup>5</sup> packaging. No metal clips may be used to close the packaging.

## 2.2.4. Specific requirements for the packaging

Packaging should be filled with sorted<sup>6</sup> materials if no other procedure has been agreed. Furthermore have to pack all order positions to one order individually. This applies in particular to sensitive components. It must be clear on which side you need to open the package – this must be marked<sup>7</sup>.

### Packaging of set articles

All parts which belong to one set (= order position consisting of several item numbers), must always be physically assigned to the set. The full set must be packed in one load unit. This refers to all parts of the set, including add-on pieces, installation material or C-material. Moreover, an abstract of components which belongs to the set should be attached. Separate material supplies, which also belongs to the set should be approved from the purchasing department.

<sup>2</sup> e.g. atmospheric influences when loading and unloading

<sup>3</sup> except bulk goods

<sup>4</sup> e.g. coated, painted, electronic, glazed components

<sup>5</sup> electrostatic discharge

<sup>6</sup> according to STAP-Item-number per package

<sup>7</sup> except visible packages

Doc.No.: KP-12.MA-02	Stadler Deutschland GmbH	Version:	Release Date:	Created:	Checked:	Approved:
	Logistics Guideline	6.0	27.01.2022	D. Grzywna	T. Mader	A. M. Lang

## 2.2.5. Structure of non-standard load carriers

In principle, the respective load carrier must be suitable for the material

- Material may not e.g. protrude over the edge
- Maximum volume utilization should be achieved
- It must be possible for a forklift truck to pick up the load carrier via the short or long side (see Figure 4). To this end, the substructure of the load carrier must be at least 150 mm high.
- the load carrier must be designed so that there is no slippage when stacked
- They should be stackable and collapsible.

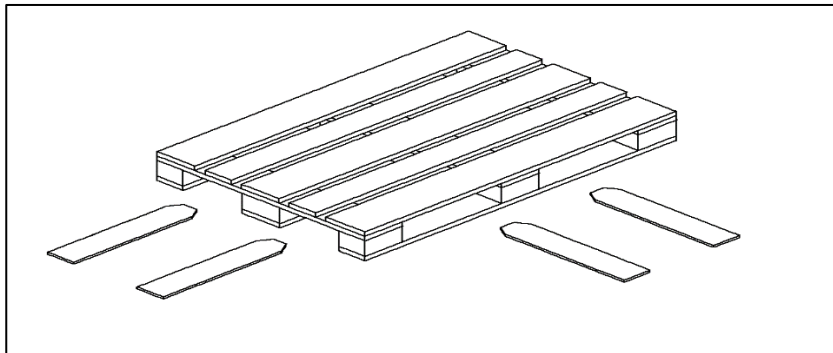

Figure 4: Picking up the load carrier

Screwing inside the load carriers or lids should be avoided. Instead, quick-release fasteners should be used with reusable load carriers. If the load carrier should be screwed from the inside, it is important to grease the screws before applying.

## 2.2.6. Economic and ecological aspects

When producing and using load carriers and packaging materials, care should be taken to design them based on economic and ecological factors.

To this end, standard load carriers should be used as far as possible<sup>8</sup>. If this is not possible, returnable systems made of recyclable materials should be used.

<sup>8</sup> see 2.2.1. Division of the load carrier

Doc.No.: KP-12.MA-02	Stadler Deutschland GmbH	Version:	Release Date:	Created:	Checked:	Approved:
	<a href="#">Logistics Guidline</a>	6.0	27.01.2022	D. Grzywna	T. Mader	A. M. Lang



## 2.3. Formation and description of the delivery

The defined delivery variants serve to identify and define the correct delivery form

- **Delivery variant 1** (delivery without load carrier)<sup>2</sup>
- **Delivery variant 2** (delivery on standard load carrier)<sup>3</sup>
- **Delivery variant 3** (delivery on non-standard load carrier with standard release)
- **Delivery variant 4** (delivery on non-standard load carrier only with special release)

Attachment 2 can be used to select a delivery variant.

### 2.3.1. Description of the delivery

Detail description of the delivery variants 1, 2, 3 and 4

Table 1: Description of the delivery variants

	Delivery variant 1	Delivery variant 2	Delivery variant 3	Delivery variant 4
Material	See order			
Load unit				In this type of delivery, the non-standard load carriers may be used after Stadler Deutschland GmbH has approved them.
Weight	≤ 30 kg	≤ 1.000 kg	≤ 2.000 kg	
Length	≤ 600 mm	≤ 1.200 mm	≤ 2.400 mm	
Width	≤ 600 mm	≤ 800 mm	≤ 800 mm	
Height	≤ 600 mm	≤ 1.100 mm	≤ 1.100 mm	
Load carrier	No load Carrier required	Standard load carrier <sup>9</sup> (e.g. euro pallet, lattice box pallet)	Non-standard load carrier <sup>10</sup> (e.g. stake rack)	Non-standard load carrier. Load carrier must be released by Stadler Deutschland GmbH <sup>11</sup>
Packaging	E.g. box	E.g. box, e.g. stretch film etc.	E.g. tarpaulin, e.g. stretch film, e.g. box	
Label	Material, packaging and load unit	Material and packaging	Material, packaging, load carrier, load unit	
Shipping documents	Delivery note, if nec. certificate, if nec. waybill, if nec. customs documents, if nec. packing list			
Transport and dispatch	E.g. parcel service, freight carrier	E.g. by a freight carrier		
Packaging Concept <sup>12</sup>	No	No	Yes	Yes

<sup>9</sup> see 2.2.1. Division of the load carrier

<sup>10</sup> on request, we can send you a catalogue with the approved load carriers

<sup>11</sup> see 2.2.5 Structure of non-standard load carriers

<sup>12</sup> packaging concept should be matching with the perspective purchaser, approval by logistics

Doc.No.: KP-12.MA-02	Stadler Deutschland GmbH	Version:	Release Date:	Created:	Checked:	Approved:
	Logistics Guideline	6.0	27.01.2022	D. Grzywna	T. Mader	A. M. Lang

## 2.3.2. Formation of the delivery

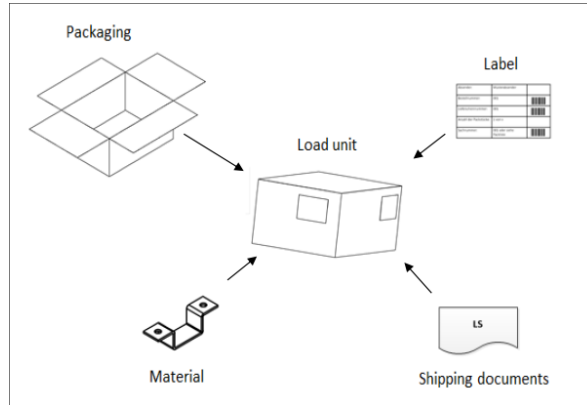

Figure 5: Creation of a load unit for delivery variant 1

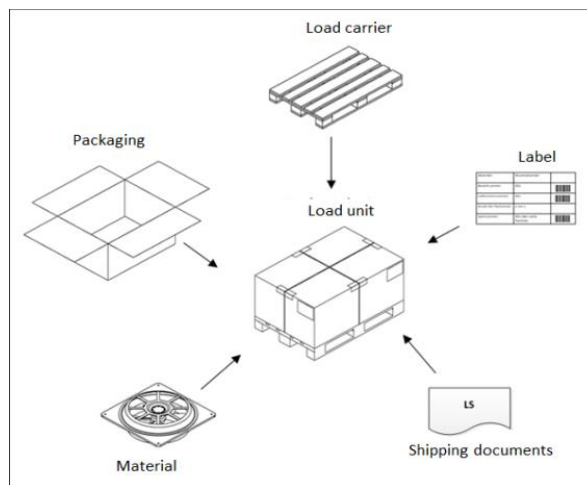

Figure 6: Creation of a load unit for delivery variant 2

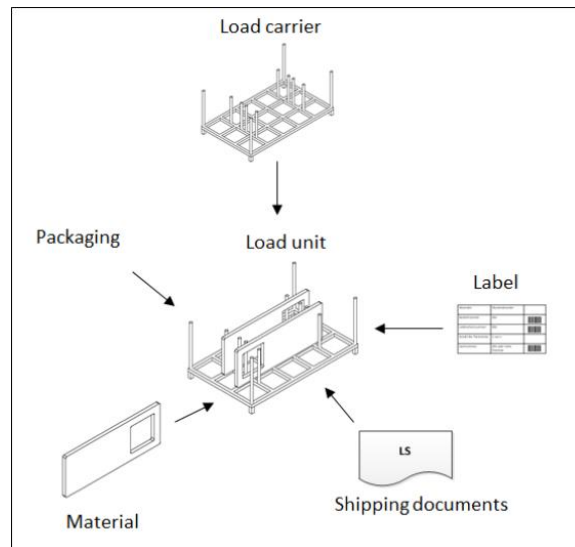

Figure 7: Creation of a load unit for delivery variant 3

Doc.No.: KP-12.MA-02	Stadler Deutschland GmbH	Version:	Release Date:	Created:	Checked:	Approved:
	Logistics Guideline	6.0	27.01.2022	D. Grzywna	T. Mader	A. M. Lang

## 3. Labelling

The labelling of load carrier, materials and load units serves fast recognition and assignment of the deliveries and materials. Stadler Deutschland GmbH must agree exceptions in writing in advance.

### 3.1. Labelling materials

All materials must be marked with the Stadler Deutschland GmbH item number according to the order. A label bearing the item number must be attached securely (so that it cannot be lost) on the reverse side of the part.

#### 3.1.1. Minimum requirements of the label and print

The requirements of the format and quality for the item number and item label are identically.

The requirements made of the label and print are as follows:

- Length: min. 30 mm
- Height: min. 10 mm
- Font size: min. 12 Punkt
- Quality of the label: It must be possible to completely remove the label from The part.
- Quality of the print: The print must be waterproof
- Barcode: Code 128 (DIN EN 799-1995)
- Spec. Barcode: Waterproof, lifespan at least > 10 years, not non-destructive to remove

The labels must be attached securely (so that it cannot be lost) on the components or the overpack. The labels are not allowed to be attached on visible area or joinings (e.g. holes, splices- or welded joints)

#### 3.1.2. Identification of components with item number

All materials must be marked with the item number from Stadler Deutschland GmbH according to the order. Components which are smaller than **40 mm x 20 mm**<sup>13</sup> don't need a labelling instead the direct package must be marked with a label.

- Text: Stadler Deutschland GmbH item number
- Barcode<sup>14</sup>: Stadler Deutschland GmbH item number (according to the order)

<sup>13</sup> length x width

<sup>14</sup> barcode mandatory by 31.03.2022

Doc.No.: KP-12.MA-02	Stadler Deutschland GmbH	Version:	Release Date:	Created:	Checked:	Approved:
	Logistics Guideline	6.0	27.01.2022	D. Grzywna	T. Mader	A. M. Lang

### 3.1.3. Identification of components with required serial numbers

Components that are equipped with a serial number due to supplier or customer specifications must be marked with the same. For this purpose, the serial number must be reliably affixed to the component and to the packaging using a label. In addition, the serial number must be uniquely assigned to a component on the delivery note and marked there as a barcode. The serial number on the label must be preceded by the prefix "S / N:" of the serial number for clear identification (for example S/N: 93U61456).

- Text: Prefix „S/N:“ + serial number
- Barcode<sup>15</sup>: Item-serial number as a barcode (without prefix)

### 3.2. Labelling packaging

All label units have a double execution. Once at the face side and once at the long side (Figure 9). If the label unit have more than one packages, every single package needs to get labeled in double execution (also once at the face side and once at the long side). A packing list<sup>16</sup> is as well important to equip (Figure 10).

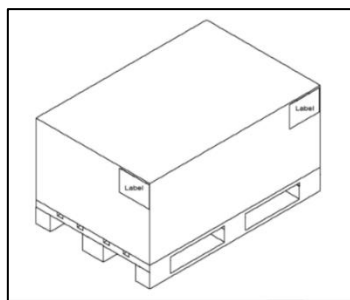

Figure 8: Labelling load units

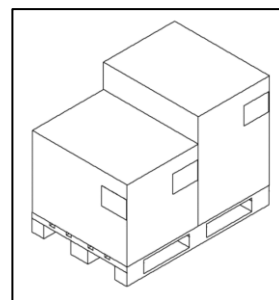

Figure 9: Load unit with several packages

If the length of the load unit exceeds 1.5 m and has a displaced centre of gravity starting from the centre), this also needs to be indicated on the load unit via labels.

#### 3.2.1. Minimum requirements for the label and print

The label should have the following format:

- Format: min. DIN A5 landscape
- Paper: white
- Front size: min. 16
- Barcode: Code 128 or ITF

<sup>15</sup> barcode mandatory by 31.03.2022

<sup>16</sup> see 4.2 Packing list

Doc.No.: KP-12.MA-02	Stadler Deutschland GmbH	Version:	Release Date:	Created:	Checked:	Approved:
	Logistics Guidline	6.0	27.01.2022	D. Grzywna	T. Mader	A. M. Lang

### 3.2.2. Content of the label

The label must contain at least the following information in the given sequence:

1. Sender (Name)
2. STAP delivery number (add. as a Barcode)<sup>17</sup>
3. STAP order number (add. as a Barcode)
4. Delivery note number (add. as a Barcode)
5. Number of packages (x/y)
6. Item number or packing list (add. as a Barcode)





Sender:	Sample sender	
Delivery number:	001	
Order number:	001	
Delivery note number:	001	
Number of packages:	1 of x	
Item Number:	001 or see packing list	

Figure 10: Sample label

### 3.3. Labelling non-standard load carriers

Non-standard load carriers need to be labelled, if they are also used as returnable load carriers. These load carriers must be labelled as follows:

- Production date of the load carrier
- Usage type: returnable load carrier
- Weight of the load carrier
- Load-bearing capacity of the load carrier (e.g. as a stacking factor)
- Load of the load carrier
- Outer dimensions of the load carrier
- Owner of the load carrier

### 3.4. Other labeling

The provider has to apply special transport and warehouse requirements on the packages (e.g. temperature sensitive commodity). The purchaser needs to know these kind of special transport- and warehouse requirements duly and written.

<sup>17</sup> supplement by 31.03.2022, requirement for SAP

Doc.No.: KP-12.MA-02	Stadler Deutschland GmbH	Version:	Release Date:	Created:	Checked:	Approved:
	<a href="#">Logistics Guideline</a>	6.0	27.01.2022	D. Grzywna	T. Mader	A. M. Lang

## 4. Shipping documents

The supplier is responsible for ensuring that the shipping documents are correct, available and that they correspond to the supplied goods.

### 4.1. Delivery note

If a delivery comprises several dispatch units, the delivery note must always be enclosed with the first unit (1/x) (incl. a copy). Also, a delivery note may only state, as a maximum, the position (about the load units) that are on the vehicle (e.g. lorry).

The delivery note should also contain the following information:

- Format: A4 Paper
- Print: must be printed in black
- Edge: A min. margin of 2.5 cm is required on the left side

The delivery note must also contain the information as a minimum requirement:

- Name of sender
- Recipient (e.g. Stadler Deutschland GmbH)
- Stadler Deutschland order number
- Delivery note number
- Dispatch date
- Stadler Deutschland item number(s)
- Quantity per item number (unit, l, kg, etc.)
- Item serial number and Barcode (serial number requirement)
- Expiration date
- Page number (x/y)
- Transport details
- Delivery conditions
- Error message or complaint number

The delivery note – if available - should also contain the following information:

- Stadler Deutschland drawing number (s)
- Charge code
- Stadler Deutschland project number (s)
- Gross and net weight

Doc.No.: KP-12.MA-02	Stadler Deutschland GmbH	Version:	Release Date:	Created:	Checked:	Approved:
	<a href="#">Logistics Guideline</a>	6.0	27.01.2022	D. Grzywna	T. Mader	A. M. Lang

## 4.2. Packing list

A packing list provides information about the type and scope of a load unit. It must be enclosed with the package, if it contains several different materials (item numbers).

The following information needs to be stated on the packing list as a minimum requirement:

- Name of sender
- Delivery note number
- Number of packages (x/y)
- Content of the respective package<sup>18</sup>
- Quantity per item number

## 4.3. Consignment note or waybill

The freight documents need to be filled in compliance with DIN 5018:2011-04<sup>19</sup>.

## 4.4. Customs clearance and customs documents

The necessary customs documents for the goods need to be enclosed with all deliveries from non-EU countries. The supplier has to ensure this. Missing or incorrect customs documents lead to delays or customs duties, which must be held responsible and borne by the supplier.

Complete customs documents include:

### Customs invoice – content:

- Name and address of consignor
- Name and address of the invoice recipient
- Name and address of the recipient
- Contact person of the consignor
- EORI number (DE 4 569 792) and VAT number (DE 196 736 771) of the invoice recipient
- Place and date of invoice
- Invoice number
- Customer references (order number, order number, etc.)
- Shipping method (trucks, ocean freight, etc.)
- Bank details and VAT number of the consignor
- Payment conditions

<sup>18</sup> if there is a Stadler Deutschland GmbH item number, this must always be stated.

<sup>19</sup> business forms – Shipping order

Doc.No.: KP-12.MA-02	Stadler Deutschland GmbH	Version:	Release Date:	Created:	Checked:	Approved:
	<a href="#">Logistics Guidline</a>	6.0	27.01.2022	D. Grzywna	T. Mader	A. M. Lang

- Incoterms® with indication of the version
- Unique article number Supplier and Stadler ID
- Customs tariff number (HS code) per item
- Meaningful description of products per article
- Value of goods and currency per item with unit price
- Country of origin and preferential status per item
- Proof of preference (declaration of origin on the invoice up to 6.000 € or EUR. 1)
- Authorization number in the case of approved exporter
- All additional costs, such as inspection, set-up, quality, packaging, tools, certification and analysis costs and values for supplies.
- Number Packages, volumes, net and gross weight, if no packing list is established
- Information on international export controls for each item (export control number EKN, ECCN, AL number for e. g. dual-use goods)

### Proof of preferential treatment (origin of product)

- Up to € 6,000 a declaration on the customs invoice has to be made and signed
- From € 6,000, a movement certificate EUR1 stamped by the customs office with reference to the customs invoice must be drawn up.
- Is the Supplier “Approved exporter”, the authorization number must be entered on the invoice.
- Stadler Germany buys duty-free.

**Lack of preferences may lead to customs duties and expenses at “Stadler Deutschland GmbH”, both of which are to be borne by the supplier.**

**Customs agent of Stadler Deutschland GmbH:** Schenker Deutschland AG

Customs office  
 Hellersdorfer Weg 35  
 12 689 Berlin  
 +49/30/3012995-710  
 zbm.berlin@dbschenker.com

Doc.No.: KP-12.MA-02	Stadler Deutschland GmbH	Version:	Release Date:	Created:	Checked:	Approved:
	Logistics Guideline	6.0	27.01.2022	D. Grzywna	T. Mader	A. M. Lang



## 5. Supply process

### 5.1. Procurement process

The order is the basis for every delivery. The procurement process regulated additional to the order through the procurement guideline.

### 5.2. Outgoing goods inspections

Stadler Deutschland GmbH asks its suppliers to perform an outgoing goods inspection before delivering goods. Attachment 3 "Checklist for inspection of outgoing goods to Stadler Deutschland GmbH" or a similar document is recommended. If Stadler detects deviations repeatedly, it may become mandatory to deliver a completed checklist.

### 5.3. Loading and unloading

The statutory regulations governing the securing of loads<sup>20</sup> must be observed when loading load units.

Stacked load units must be vertical. Also, when stacking load units, the load unit with the heaviest gross weight must be stacked at the bottom.

In addition, the load units must be loaded so that they can be moved easily with a forklift 2t without additional help. If this is not possible, this must be agreed first with Stadler Deutschland GmbH and approved.

### 5.4. Transport and dispatch

If all requirements stated in the previous chapters have been fulfilled, the packed load units can be sent to Stadler Deutschland GmbH.

#### 5.4.1. Shipping instruction inbound

Stadler Deutschland GmbH has concluded agreements with logistic service providers for the procurement of our materials. Please note the following shipping instructions for sending our EXW / FCA orders from now on:

<sup>20</sup> german road traffic regulations (StVO) §22

Doc.No.: KP-12.MA-02	Stadler Deutschland GmbH	Version:	Release Date:	Created:	Checked:	Approved:
	<a href="#">Logistics Guidline</a>	6.0	27.01.2022	D. Grzywna	T. Mader	A. M. Lang

**1. Goods up to 30 kg / parcel shipping / within EU / courier**

**Register at TNT with our customer number: XXXXXXX**

Phone: 01806 900 800 \*

**2. Goods up to 30 kg / parcel dispatch / from EFTA or third countries / courier**

**Registration at DHL with our customer number: XXXXXXX**

Telephone: 0180 6 345300-3

Website: [www.dhl.de/express](http://www.dhl.de/express)

**3. Goods > 30 kg / pallets / piece goods / partial lots up to 1.5 loading meters or 1500 kg**

**Register at DB Schenker with our customer number: XXXXX**

Telephone: 033 701/360 444

Fax: 033 701/360 449

Email: [grossbeeren.kundenservice@dbschenker.com](mailto:grossbeeren.kundenservice@dbschenker.com)

Website: <https://eschenker.dbschenker.com>

**4. Partial and complete lots > 1.5 loading meters or 1500 kg**

**Registration at WWI Logistik GmbH, Lessingstr. 79, D-13158 Berlin**

Phone: +49 (0) 3041938073

Fax. +49 (0) 30/420 824 713

Email: [michael.wenke@wwilog.com](mailto:michael.wenke@wwilog.com)

Our shipment reference indicates all service provider as a **order-number and consignment-number**. We will no longer approve or adjust transport costs for the shipment of goods except the above-mentioned logistics service provider. For any inquiries please don't hesitate to contact the Stadler shipping department or the particular Stadler purchase department. Please note our current valid purchase- and order-requirements. You will find the suitable customer number for the registration at TNT, DHL or DB Schenker in our orders or, if necessary, requested from the contact person given below.

**Shipping department:** [STAP-Versand@stadlerrail.com](mailto:STAP-Versand@stadlerrail.com)

**5.4.2. Address Stadler Deutschland GmbH**

**Address central warehouse**

Stadler Deutschland GmbH  
Triftstr. 37-38  
Warenannahme / Halle 2  
13509 Berlin

**Address direct delivery**

Stadler Deutschland GmbH  
Lessingstraße 102  
13158 Berlin

When booking or writing assignments, please consider that Stadler Deutschland GmbH is illustrated as the client and measures our different delivery address.

Doc.No.: KP-12.MA-02	Stadler Deutschland GmbH	Version:	Release Date:	Created:	Checked:	Approved:
	Logistics Guidline	6.0	27.01.2022	D. Grzywna	T. Mader	A. M. Lang

**Customer:**

Stadler Deutschland GmbH  
 Lessingstrasse 102, 13158 Berlin.

The delivery address is the respective agreed delivery place.

**5.4.3. Dispatch of hazardous good**

When shipping hazardous goods, the respective latest version of the ADR<sup>21</sup> must be observed and applied. Also, the respective statutory regulations need to be observed and applied.

**5.5. Delivery**

**5.5.1. Opening times incoming goods**

The opening times of the incoming goods departments are stated on the order and are evident in the booking-tool.

**5.5.2. Registration transport**

The contractor is **as from 01.02.2022** obligated to book a time frame which the customer made available under the website: <https://rampman-stadler.logsol-gmbh.de>.

This is exclusively important for the delivery of the freight, **shipments over parcel services are not affected**. The use of the systems is for you as a business partner of the Stadler Deutschland GmbH free of charge. The time frame needs to be booked 24 hours before the delivery. Otherwise the purchaser has got the right to delay or to refuse unloading. The outcome possible claim for costs are generally refused. The vehicle which is registered to deliver must report to the receiving department **minimum 15 minutes** before the booked time frame begins. Otherwise the purchaser has got the right to delay or to refuse an unloading.

In case of a refuse of the unloading the purchaser is (regarding to the upper requirements) obligated to book a new time frame. It is important to obligate personal information for booking a time frame. The purchaser gathers these information from the information letter which was delivered to him in advance.

In case the contractor has no login data for the booking tool it is possible to use the one-time-login function or login data can also be requested by the contact person at the bottom:

**Receiving department:** [Warenannahme.STAP@stadlerrail.com](mailto:Warenannahme.STAP@stadlerrail.com)

**5.5.3. Goods acceptance**

<sup>21</sup> european agreement about the transportation of hazardous goods on the road

Doc.No.: KP-12.MA-02	Stadler Deutschland GmbH	Version:	Release Date:	Created:	Checked:	Approved:
	<a href="#">Logistics Guidline</a>	6.0	27.01.2022	D. Grzywna	T. Mader	A. M. Lang

The condition for the acceptance of the order that is delivered is that all materials are free from qualitative and quantitative defects and the delivery documents are completely present. Beside the requirements in this guideline it is appropriate to meet the requirements which are notified in the order or are determinate in the quality- and procurement-guidelines. Especially used load carrier must be free from defects. All deliveries are accepted under reservation.

Faulty deliveries will be returned at the supplier's expense or the delivery can be rejected. A non-faulty partial delivery that belongs to a faulty delivery may also be returned

## 5.6. Empties management

Stadler Deutschland GmbH exchanges the following load carriers and auxiliary materials in the incoming goods department:

- Euro pallets acc. to DIN EN 13698
- Lattice box pallets acc. to DIN EN 13626
- Wooden stacking frame (1200 x 800 x 200) mm
- RL- KLT (3147, 4280, 4147)

These load carriers and auxiliary materials are only exchanged in the incoming goods departments if they are undamaged and in a good condition. If there are inadequate supplies, if load carriers and auxiliary materials available for exchange, the respective supplier/freight carrier is issued a signed empties voucher which authorizes the owner to pick

up the load carriers and auxiliary materials at a later date.

Please contact the number below if you want to return load carriers.

The contact partner for empties management is:

**Empties management:** STAP.leergutmanagement@stadlerrail.com

Doc.No.: KP-12.MA-02	Stadler Deutschland GmbH	Version:	Release Date:	Created:	Checked:	Approved:
	Logistics Guideline	6.0	27.01.2022	D. Grzywna	T. Mader	A. M. Lang

**6. Enclosure**

**6.1. Attachment 1: Different regulation of the logistics guideline**

Supplier: \_\_\_\_\_

Street and house number: \_\_\_\_\_

Postal code and city: \_\_\_\_\_

In deviation from the logistics guideline the following additional agreements are reached:

---

---

---

---

---

---

---

---

---

---

---

---

---

---

---

---

---

---

---

---

---

---

---

---

\_\_\_\_\_  
Date and signature  
Stadler Deutschland GmbH

\_\_\_\_\_  
Date and signature  
Supplier

Doc.No.: KP-12.MA-02	Stadler Deutschland GmbH	Version:	Release Date:	Created:	Checked:	Approved:
	Logistics Guideline	6.0	27.01.2022	D. Grzywna	T. Mader	A. M. Lang

## 6.2. Attachment 2: Selection of the load units

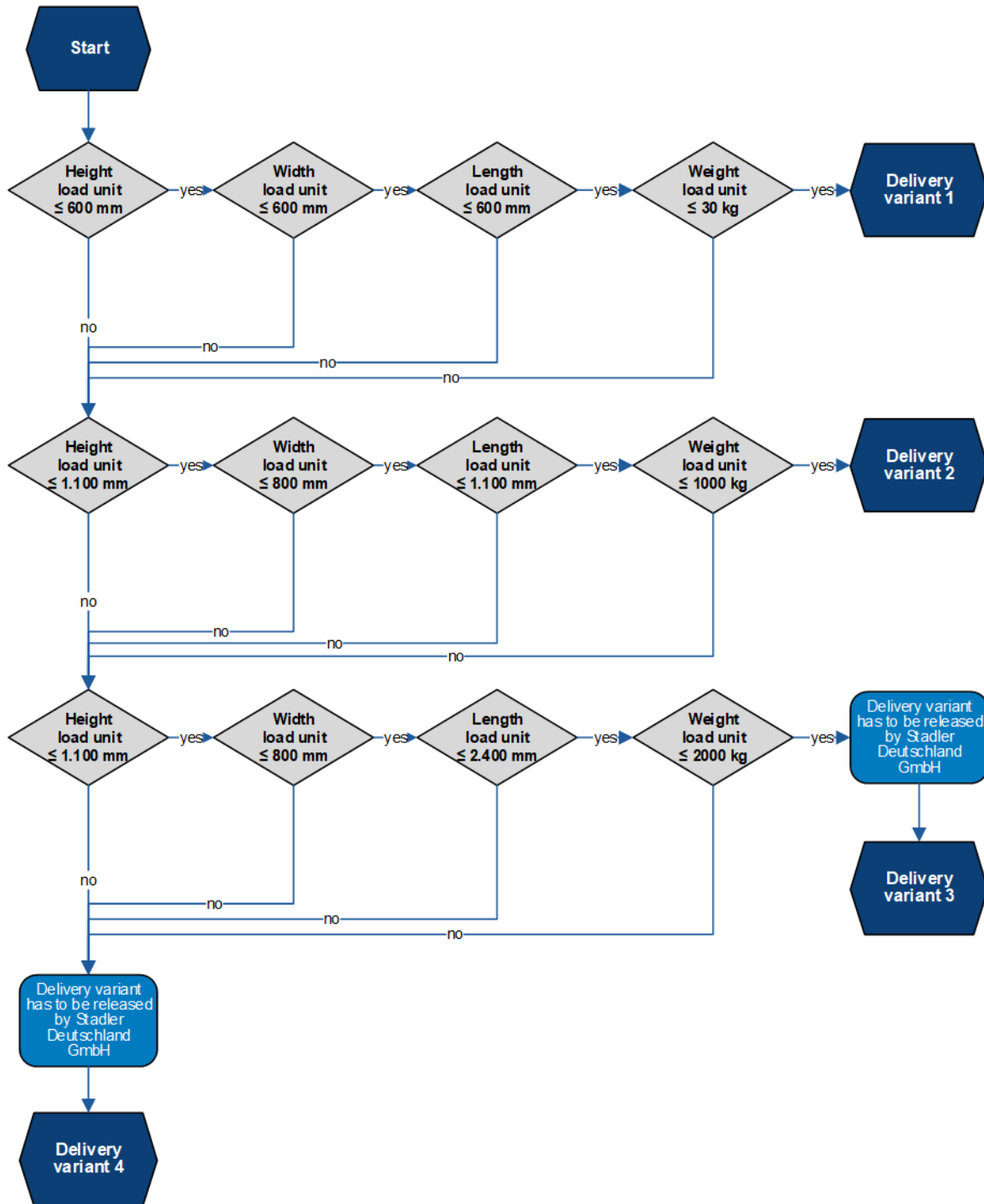

Doc.No.: KP-12.MA-02	Stadler Deutschland GmbH	Version:	Release Date:	Created:	Checked:	Approved:
	Logistics Guideline	6.0	27.01.2022	D. Grzywna	T. Mader	A. M. Lang

## 6.3. Attachment 3: Checklist for inspection of outgoing goods to Stadler Deutschland GmbH

Supplier: \_\_\_\_\_ Delivery Receipt: \_\_\_\_\_  
 ID-No.: \_\_\_\_\_ Quantity: \_\_\_\_\_ Serial-No.: \_\_\_\_\_

- |   | Yes                      | No                       | n.a.                     |
|---|--------------------------|--------------------------|--------------------------|
| 1. The quantity of delivered goods has been checked in accordance to the delivery receipt.<br>Comment:  | <input type="checkbox"/> | <input type="checkbox"/> | <input type="checkbox"/> |
| 2. The condition of delivered goods has been checked in accordance to the currently present engineering drawing and parts list. It has been checked that there are no missing or wrongfully manufactured parts.<br>Comment: | <input type="checkbox"/> | <input type="checkbox"/> | <input type="checkbox"/> |
| 3. The delivered goods are not damaged, corroded or soiled.<br>Comment:   | <input type="checkbox"/> | <input type="checkbox"/> | <input type="checkbox"/> |
| 4. The results of the measurement test are in accordance to the currently present engineering drawing, and can be shown to a representative of Stadler Deutschland GmbH.<br>Comment:  | <input type="checkbox"/> | <input type="checkbox"/> | <input type="checkbox"/> |
| 5. The results of the functional test are in accordance to the test specification, and can be shown to a representative of Stadler Deutschland GmbH.<br>Comment:  | <input type="checkbox"/> | <input type="checkbox"/> | <input type="checkbox"/> |
| 6. The results of the coating test are in accordance to the coating specification, and can be shown to a representative of Stadler Deutschland GmbH.<br>Comment:  | <input type="checkbox"/> | <input type="checkbox"/> | <input type="checkbox"/> |
| 7. The results of the weld test are in accordance to DIN EN 15085-2, and can be shown to a representative of Stadler Deutschland GmbH.<br>Comment:  | <input type="checkbox"/> | <input type="checkbox"/> | <input type="checkbox"/> |
| 8. The results of the glue test are in accordance to DIN 6701-2, and can be shown to a representative of Stadler Deutschland GmbH.<br>Comment:  | <input type="checkbox"/> | <input type="checkbox"/> | <input type="checkbox"/> |

**We hereby confirm the completeness of the above given information and attach the delivery note (3.1 approval certificate).**

---

Date	Name / Department / Direct Dialling	Signature
------	-------------------------------------	-----------

Article that are canceled are no longer considered.

<b>Doc.No.:</b> KP-12.MA-02	Stadler Deutschland GmbH	Version:	Release Date:	Created:	Checked:	Approved:
	Logistics Guidline	6.0	27.01.2022	D. Grzywna	T. Mader	A. M. Lang